



RODIX INC.
FEEDER CUBE®
Air Blow Series
GENERAL PURPOSE



Model – AB-2
P/N 121-000-1391
Circuit Board P/N 24-236

Input: 120 VAC, 50/60 HZ.
(Operating range 90-130 VAC)
Fuse Size: 1 AMP
Output: 0-24 VDC

ADJUSTMENTS & SET UP

OVERVIEW

The Air Blow control board is used for multi-lane feeder bowl applications to blow excess parts on a lane back into the bowl.

The control board can drive the air valves on 2 lanes, and send ON/OFF control signals to the bowl and hopper feeder controls, or it can control 3 lanes, and signal the feeder bowl control.

1. POWER SUPPLY

An external 24 volt DC power supply is installed to operate the air blow board, sensors, and air valves. Size the power supply current at 450mA or greater, or else calculate the size by combining the mA draw of the board (50mA), each 24VDC air valve, and each part sensor. Add about 20% to the calculated amperage so that the power supply will operate cool.

Connect the 24 volt DC power supply to the Power “+” and “-” terminals of TB1.

2. PART SENSORS

PNP parts sensors are required for each lane used. The sensors must operate from 24 volts DC. The sensors connect to TB1. The wiring polarity is marked on the board. Each sensor input has a corresponding LED on the circuit board that is lit when the sensor output is ON. Set the DIP Switch S1 for the number of lanes needed for the application according to section 4.

3. HOPPER or LANE 3 INPUT

The Hopper Input allows a hopper to operate when the hopper sensor is calling for parts and when the bowl is feeding. The Hopper sensor input has its own invert switch labeled “INV H”. The Lane 3, DIP switch S1 should be set to the OFF position.

Set Lane 3 DIP, switch S1 to the ON position if the hopper sensor input will be used for the third parts lane instead of a hopper sensor. The “INV S” switch will control the invert sensor logic for all three lanes.

4. FEATURE PROGRAMMING SWITCH

When the “INV S” switch is ON, it will invert the lane sensor logic.

When the “INV H” switch is ON, it will invert the hopper sensor’s logic. Note: when LN 3 (lane 3) is selected, the “INV S” controls the sensor input logic.

Set “LN 3” to ON when three parts lanes are in use. (The hopper function gets disabled)

Set “C ON” (constant on) to ON when it is desirable to keep the bowl running continually, even when all the lanes are full. The air valves blow excess parts back into the bowl.

Switches SW5 through SW8 are used for special program functions and enhanced features.

5. RUN INPUT

The Run Input needs to have a 24 volt signal applied in order to activate the board’s operation.

A) The RUN input can use the internal power supply if a contact or a jumper will provide the signal. When using the internal power supply, the shorting jumper should connect across the INT pins. The RUN signal contact or jumper gets connected to TB1 terminals “+” and “PNP” of the Run Input.

B) For an externally powered run signal to control the Run Input, such as a PLC with a PNP output, set the shorting jumper across the EXT pins. The PNP output connects to the “PNP” terminal of the Run Input on TB1. The PLC common connects to the “-” terminal of the Run Input.

6. AIR VALVES

Install 24 volt DC air valves that draw 100mA or less. When a valve is ON, an LED for that output will light. If the hopper sensor input will be used for the third lane, the Lane 3 switch on DIP switch S1 must be set to the ON position.

7. LANE TIME DELAYS

Each Lane has its own set of ON delay and OFF delay trimpots. Each delay provides an adjustment from 0 to 16 seconds. Set the time delays to fill the lane to the desired level and then blow the excess parts back into the bowl.

The OFF delay (Lane Full) delay lets the lane part level build above the sensor before the lane is considered full, and the air blow turns ON. When all lanes are full, the bowl turns OFF and all air valves turn OFF. (When Constant On is used the bowl will never turn off except when the run input gets removed.)

The ON (Lane Empty) delay lets the part level empty out below the lane sensor before the lane is determined to be empty and the air blow turns OFF. The bowl turns ON when any lane is empty.

WARRANTY

Rodix Control Products are Warranted to be free from defects in material and workmanship under normal use for a period of two years from date of shipment. For the full description of the warranty, terms, and software license, please contact the factory.

For assistance installing or operating your Rodix Feeder Cube® please call the factory or visit our web site. Technical help is available to answer your questions and email any needed information. To return a control for IN or OUT of warranty service, please ship it prepaid to:

Rodix Inc., ATTN: Repair Department

If under warranty, Rodix will repair or replace your control at no charge; If out of warranty, we will repair it and you will be billed for the repair charges (Time and Material) plus the return freight. Quotes for repairs are available upon request. A brief note describing the symptoms helps our technicians address the issue.

Feeder Cube® is a registered TM of Rodix Inc.

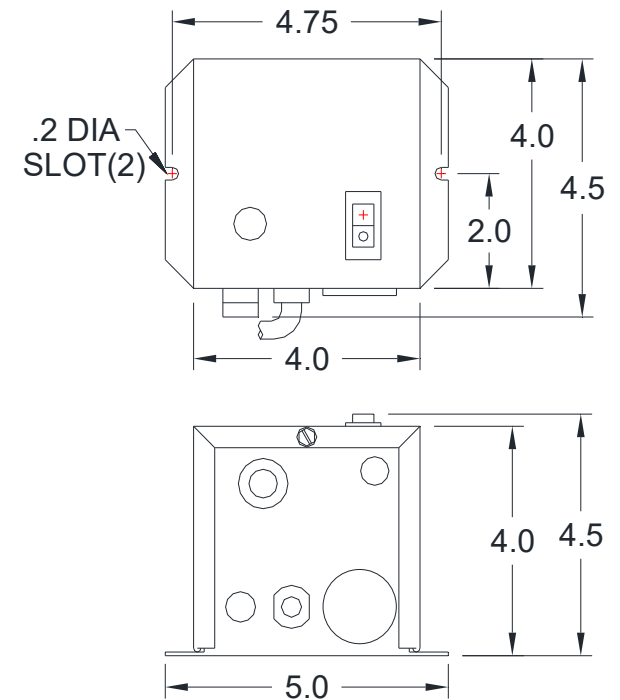

RODIX, INC. www.rodix.com
Toll Free (800) 562-1868, FAX (815) 316-4701
E-mail custserve@rodix.com



RODIX INC.
FEEDER CUBE®
 Air Blow Series
WIRING DIAGRAM

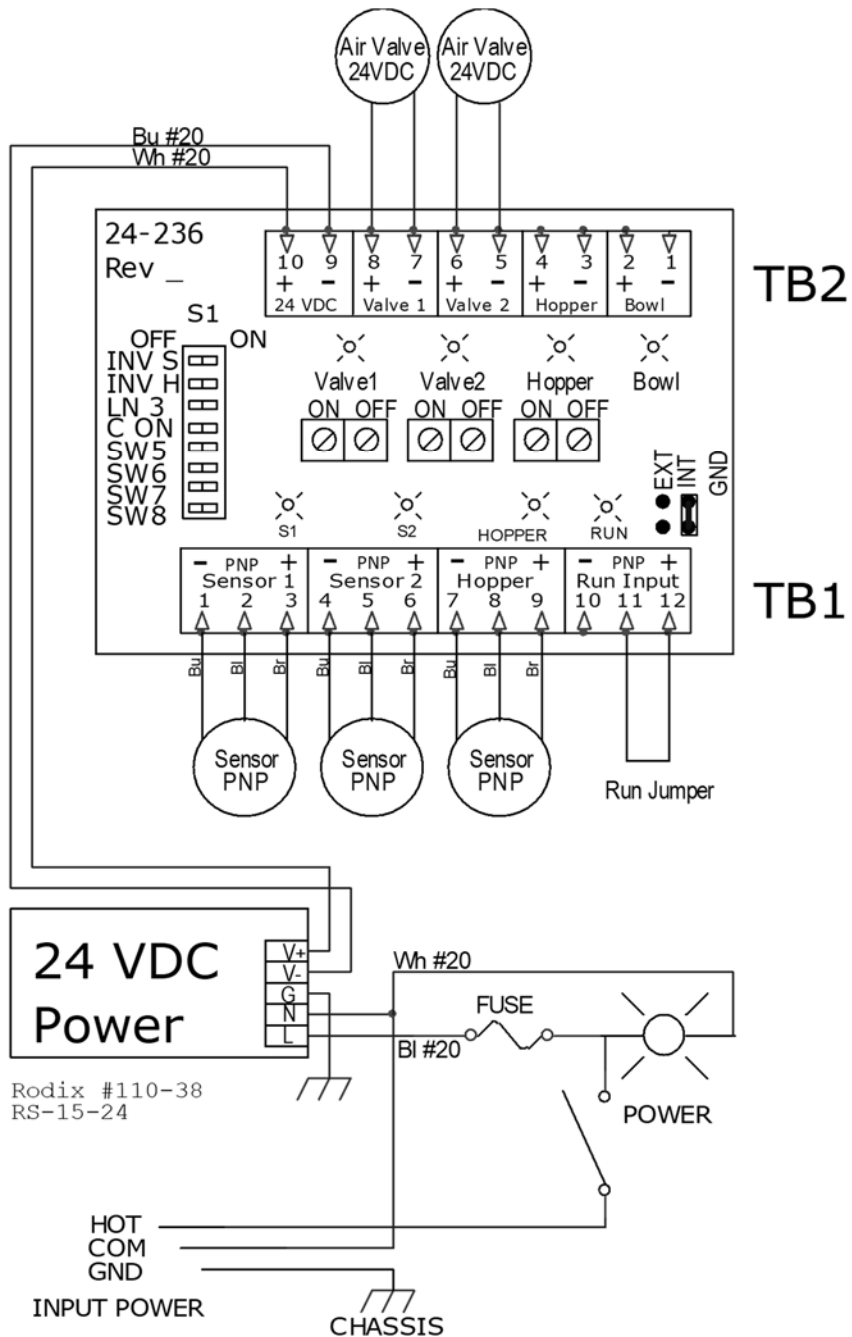

24-236 INTERNAL OR EXTERNAL GROUNDING

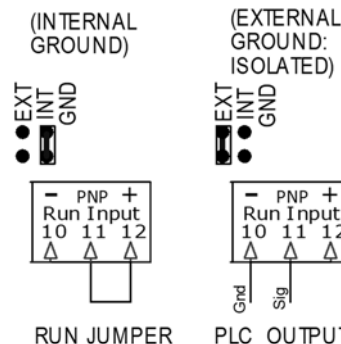

MODEL	INPUT VAC	AMP	OUTPUT
AB-2	120 VAC	1	24VDC

RODIX, INC. www.rodix.com
 Toll Free (800) 562-1868, FAX (815) 316-4701
 email custserve@rodix.com
 AB-2 121-1391.doc 1/26/2016 Page 3



RODIX INCORPORATED

2316 23rd Ave., ROCKFORD IL 61104

TOLL FREE (800) 562-1868, FAX (815) 316-4701

E-mail custserve@rodix.com

www.rodix.com

FEEDER CUBE®

AB-2 121-1391 Air Blow Series

GENERAL PURPOSE MODEL

IMPORTANT: APPLICATION NOTE